

ULINE H-1649, H-1650, H-1651
H-1653, H-1654
EASY-COUNT SCALES

1-800-295-5510
uline.com

Para Español, vea páginas 3-4.
Pour le français, consulter les pages 5-6.

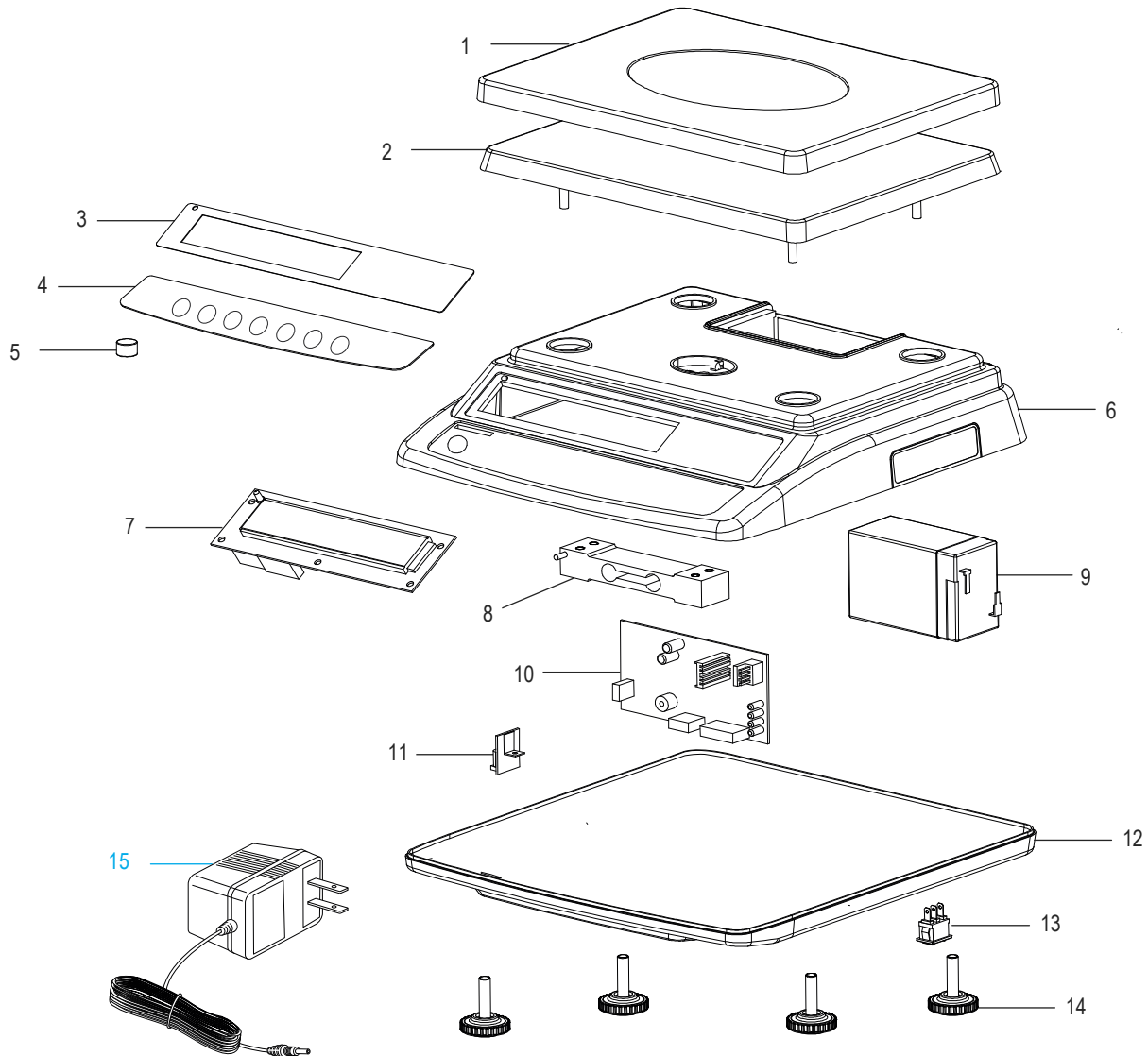

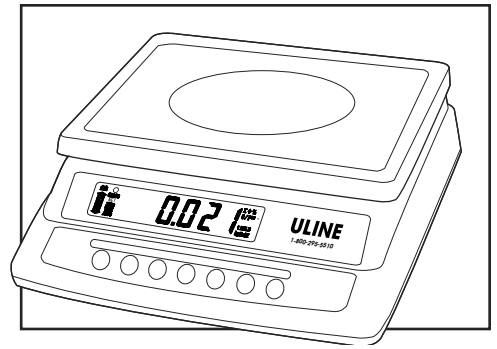

H-1649, H-1650, H-1651
H-1653, H-1654

EASY-COUNT SCALES

1-800-295-5510
uline.com

#	DESCRIPTION	QTY.	ULINE PART NO.	MFG. PART NO.
1	Stainless Steel Weighing Pan	1	H-1653-PAN	113400231
2	Plastic Weighing Pan	1	H-1650-PAN	111700127
3	Display Overlay for H-1649	1	-----	113701185
3	Display Overlay for H-1650	1	-----	113701186
3	Display Overlay for H-1651	1	H-1651-OVRLY	113701184
3	Display Overlay for H-1653	1	H-1653-DISP	113701188
3	Display Overlay for H-1654	1	H-1654-DISPQ	113701187
4	Keypad Overlay for H-1649	1	H-1649-351	113500760
4	Keypad Overlay for H-1650	1	H-1650-352	113500761
4	Keypad Overlay for H-1651	1	H-1651-353	113500762
4	Keypad Overlay for H-1653	1	H-1653-354	113500763
4	Keypad Overlay for H-1654	1	H-1654-355	113500764
5	Level Indicator	1	-----	112200009
6	Upper Housing	1	H-1651-TPCVR	111700163
7	Display Board	1	H-1650-DISP	120100366
8	Load Cell for H-1649	1	H-1649-CELL	113000430
8	Load Cell for H-1650	1	H-1650-CELL	113000422
8	Load Cell for H-1651	1	H-1651-CELL	113000746
8	Load Cell for H-1653 and H-1654	1	H-1653-CELL	113000843
9	Battery	1	H-1652	110200029
10	Mainboard	1	H-1654-MB14B	120100372
11	AC Adapter Power Socket	1	H-1651-PWRSK	120100415
12	Lower Housing	1	-----	111700333
13	On/Off Power Switch	1	H-1653-9	120300102
14	Foot	4	H-1651-FEET	111700134 111800102
15	12V AC Adapter	1	H-1679-ADAPT	111200157
	Dust Cover (Not Shown)	1	H-1651-DCVR	112700347

ULINE H-1649, H-1650, H-1651
H-1653, H-1654
**BÁSCULAS CUENTA
FÁCIL**

800-295-5510
uline.mx

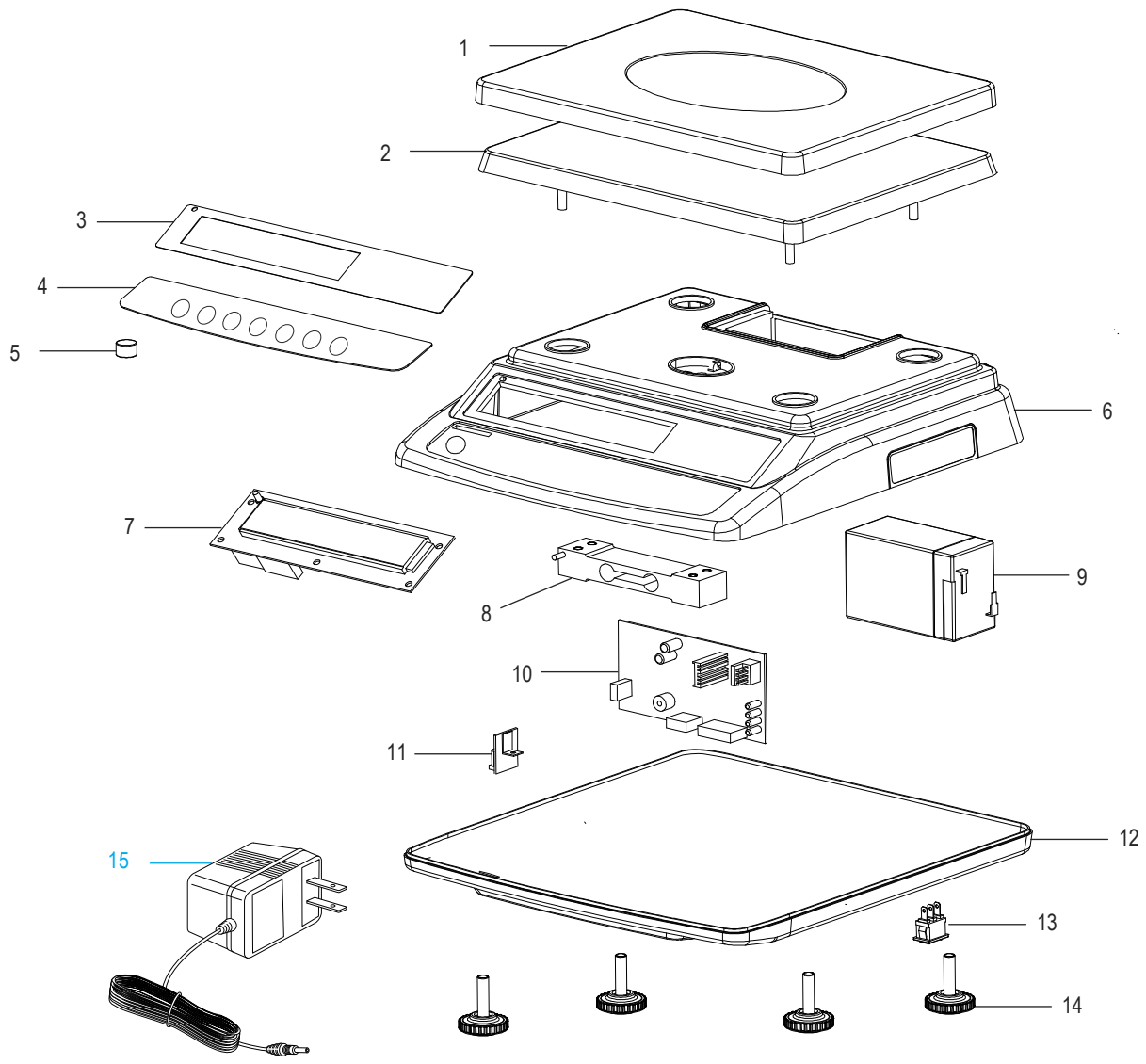
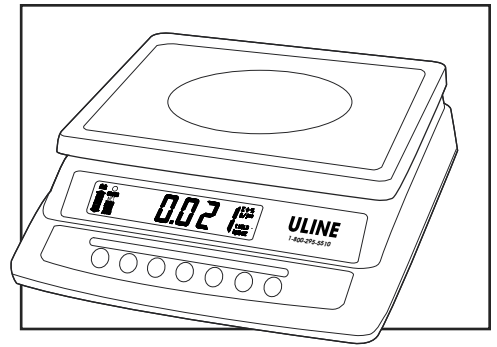



H-1649, H-1650, H-1651
H-1653, H-1654

**BÁSCULAS CUENTA
FÁCIL**

800-295-5510

uline.mx

#	DESCRIPCIÓN	CANT.	NO. DE PARTE DE ULINE	NO. DE PARTE DEL FABRICANTE
1	Plataforma de Acero Inoxidable para Pesaje	1	H-1653-PAN	113400231
2	Plataforma de Plástico para Pesaje	1	H-1650-PAN	111700127
3	Mica de la Pantalla para H-1649	1	-----	113701185
3	Mica de la Pantalla para H-1650	1	-----	113701186
3	Mica de la Pantalla para H-1651	1	H-1651-OVRLY	113701184
3	Mica de la Pantalla para H-1653	1	H-1653-DISP	113701188
3	Mica de la Pantalla para H-1654	1	H-1654-DISPQ	113701187
4	Mica del Teclado para H-1649	1	H-1649-351	113500760
4	Mica del Teclado para H-1650	1	H-1650-352	113500761
4	Mica del Teclado para H-1651	1	H-1651-353	113500762
4	Mica del Teclado para H-1653	1	H-1653-354	113500763
4	Mica del Teclado para H-1654	1	H-1654-355	113500764
5	Indicador de Nivel	1	-----	112200009
6	Cubierta Superior	1	H-1651-TPCVR	111700163
7	Tarjeta de Pantalla	1	H-1650-DISP	120100366
8	Celda de Carga para H-1649	1	H-1649-CELL	113000430
8	Celda de Carga para H-1650	1	H-1650-CELL	113000422
8	Celda de Carga para H-1651	1	H-1651-CELL	113000746
8	Celda de Carga para H-1653 and H-1654	1	H-1653-CELL	113000843
9	Batería	1	H-1652	110200029
10	Tarjeta Principal	1	H-1654-MB14B	120100372
11	Enchufe Adaptador CA	1	H-1651-PWRSK	120100415
12	Cubierta Inferior	1	-----	111700333
13	Interruptor de Encendido / Apagado	1	H-1653-9	120300102
14	Pata	4	H-1651-FEET	111700134 111800102
15	Adaptador CA de 12 Voltios	1	H-1679-ADAPT	111200157
	Cubierta para Polvo (No se Muestra)	1	H-1651-DCVR	112700347

ULINE H-1649, H-1650, H-1651
H-1653, H-1654

BALANCE COMPTEUSE SIMPLE

1-800-295-5510
uline.ca

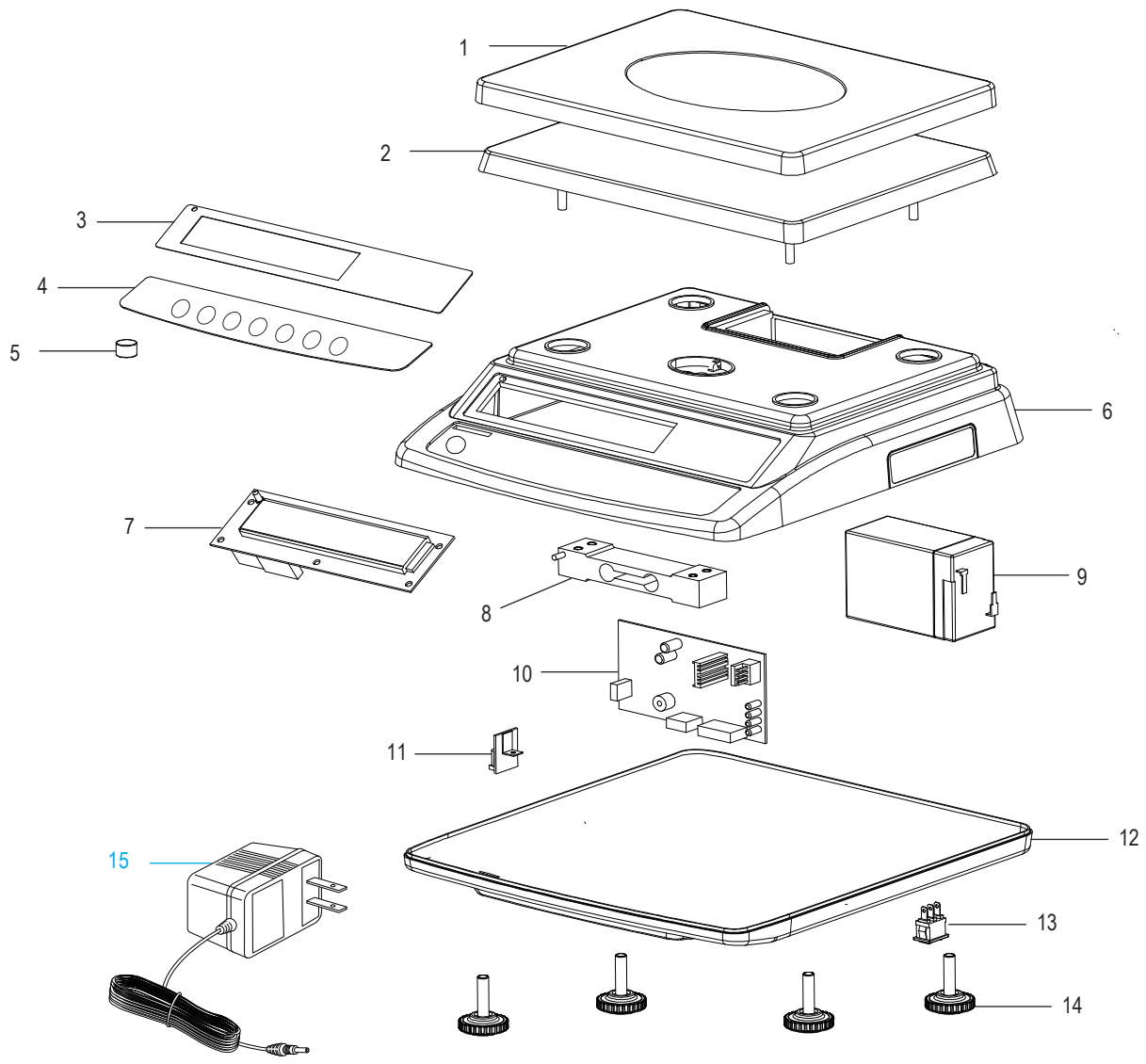
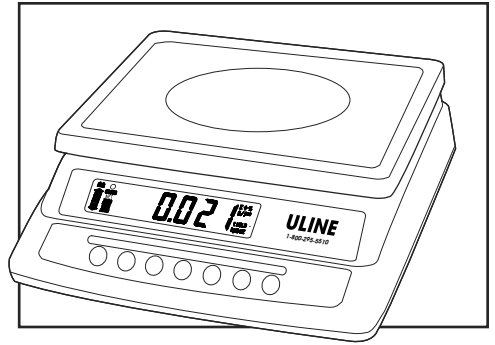

**BALANCE COMPTEUSE
SIMPLE**

#	DESCRIPTION	QTÉ	RÉF. ULINE	RÉF. DU FABRICANT
1	Plateau de pesée en acier inoxydable	1	H-1653-PAN	113400231
2	Plateau de pesée en plastique	1	H-1650-PAN	111700127
3	Afficheur revêtu pour H-1649	1	-----	113701185
3	Afficheur revêtu pour H-1650	1	-----	113701186
3	Afficheur revêtu pour H-1651	1	H-1651-OVRLY	113701184
3	Afficheur revêtu pour H-1653	1	H-1653-DISP	113701188
3	Afficheur revêtu pour H-1654	1	H-1654-DISPQ	113701187
4	Clavier à membrane pour H-1649	1	H-1649-351	113500760
4	Clavier à membrane pour H-1650	1	H-1650-352	113500761
4	Clavier à membrane pour H-1651	1	H-1651-353	113500762
4	Clavier à membrane pour H-1653	1	H-1653-354	113500763
4	Clavier à membrane pour H-1654	1	H-1654-355	113500764
5	Indicateur de niveau	1	-----	112200009
6	Boîtier supérieur	1	H-1651-TPCVR	111700163
7	Tableau d'affichage	1	H-1650-DISP	120100366
8	Cellule de poids pour H-1649	1	H-1649-CELL	113000430
8	Cellule de poids pour H-1650	1	H-1650-CELL	113000422
8	Cellule de poids pour H-1651	1	H-1651-CELL	113000746
8	Cellule de poids pour H-1653 and H-1654	1	H-1653-CELL	113000843
9	Pile	1	H-1652	110200029
10	Carte mère	1	H-1654-MB14B	120100372
11	Prise de courant de l'adaptateur c.a.	1	H-1651-PWRSK	120100415
12	Boîtier inférieur	1	-----	111700333
13	Interrupteur marche / arrêt	1	H-1653-9	120300102
14	Pied	4	H-1651-FEET	111700134 111800102
15	Adaptateur c.a. de 12V	1	H-1679-ADAPT	111200157
	Housse anti-poussière (non illustré)	1	H-1651-DCVR	112700347