

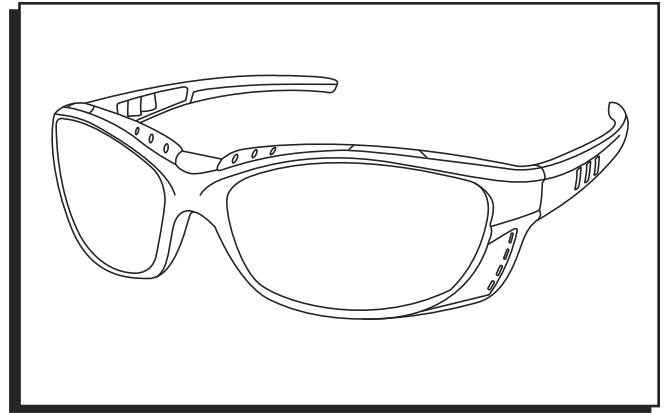

ULINE S-20722
LIVEWIRE™
SAFETY GLASSES

1-800-295-5510
uline.com



CONVERTING TO GOGGLES

 **NOTE:** Frame and lenses are made of polycarbonate and will not break during goggle assembly.

1. Fold the arm into the closed position. (See Figure 1)

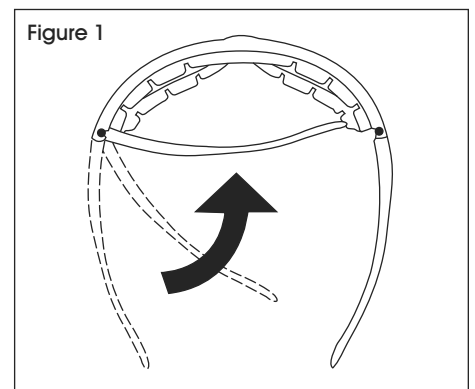

2. Rotate the arm straight down until the arm snaps out of the hinge. (See Figure 2)

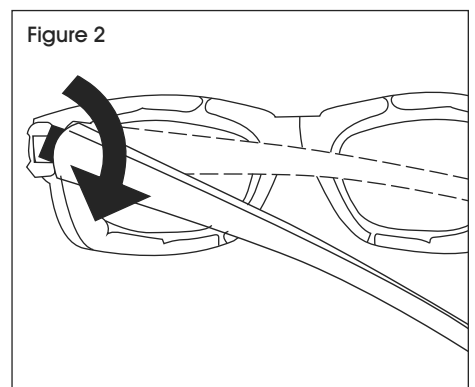

3. Insert the bottom of the goggle clip into the hinge slot in the frame. Rotate upward until it snaps into place. (See Figure 3)

4. Repeat steps 1 through 3 for other arm.

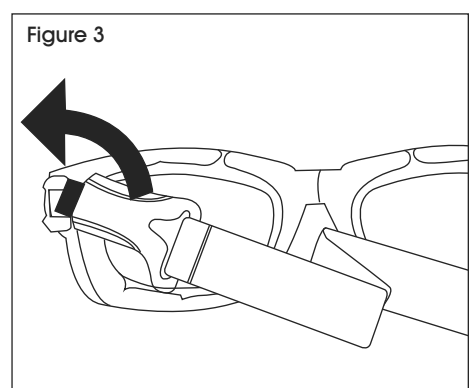

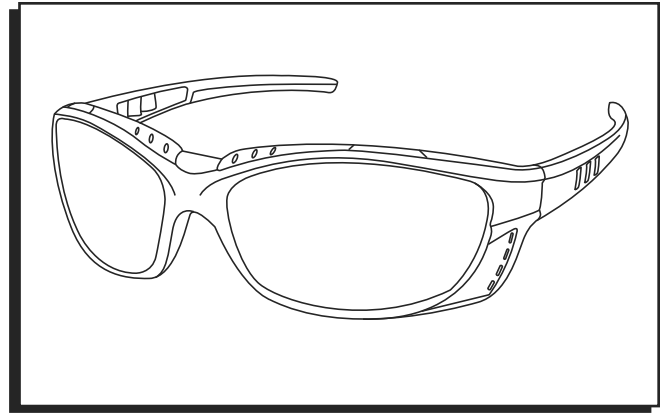

CONVERTIR A GOGGLES



NOTA: El marco y las lentes están fabricados en policarbonato y no se romperán durante el ensamble de las goggles.

1. Doble el brazo a la posición de cierre. (Vea Diagrama 1)
2. Gire el brazo completamente hacia abajo hasta que se salga de la bisagra. (Vea Diagrama 2)
3. Inserte la parte inferior del clip de google en la ranura de la bisagra del marco. Gire hacia arriba hasta que calce en su sitio. (Vea Diagrama 3)
4. Repita los pasos 1 y 3 para el otro brazo.

Diagrama 1



Diagrama 2



Diagrama 3



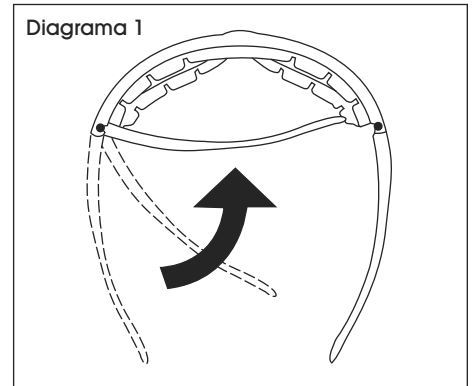

CONVERTIR EN LUNETTES PROTECTRICES

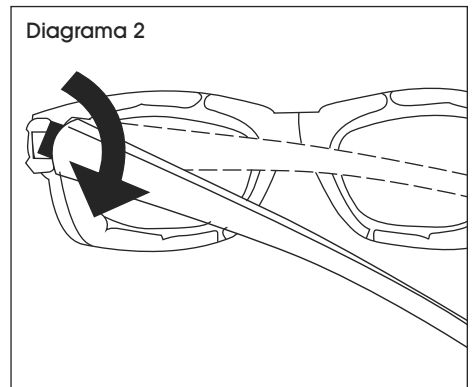
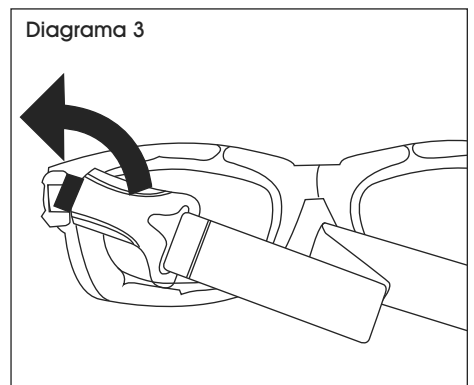
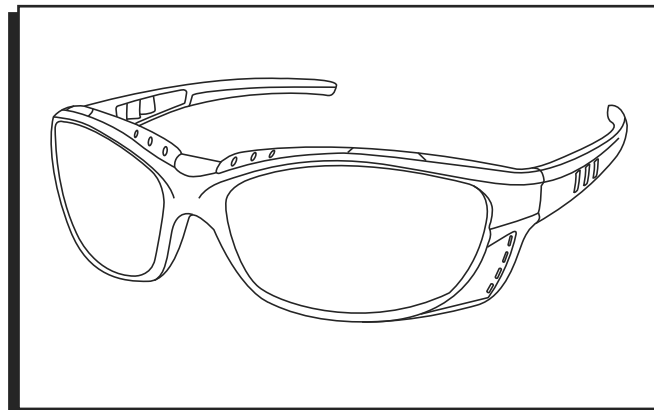

REMARQUE : La monture et les verres sont en polycarbonate et ne seront pas brisés lors de la conversion en lunettes protectrices.

1. Pliez la branche en position fermée. (Voir Figure 1)

Figure 1

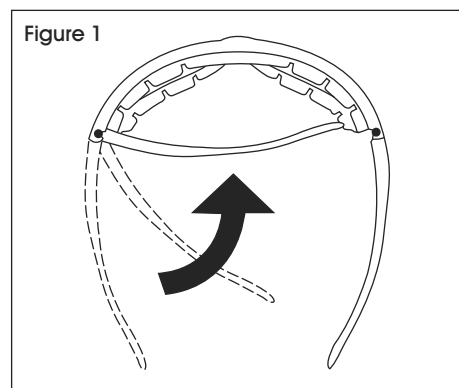

2. Tournez la branche directement vers le bas jusqu'à ce qu'elle sorte de la charnière. (Voir Figure 2)

Figure 2

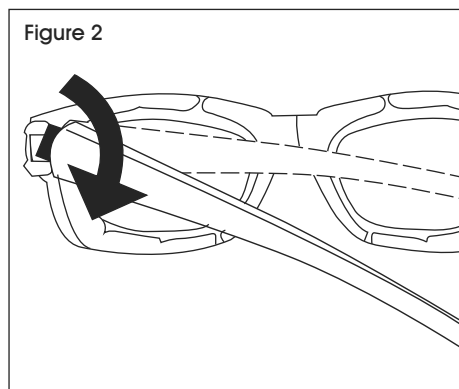

3. Insérez la partie inférieure de l'attache de lunettes protectrices dans la fente de la charnière de la monture. Tournez vers le haut jusqu'à ce qu'elle s'enclenche en position. (Voir Figure 3)
4. Répétez les étapes 1 à 3 pour l'autre branche.

Figure 3

