

# ULINE H-5070 FOLDING CART

1-800-295-5510  
uline.com

## TOOL NEEDED



Rubber Mallet

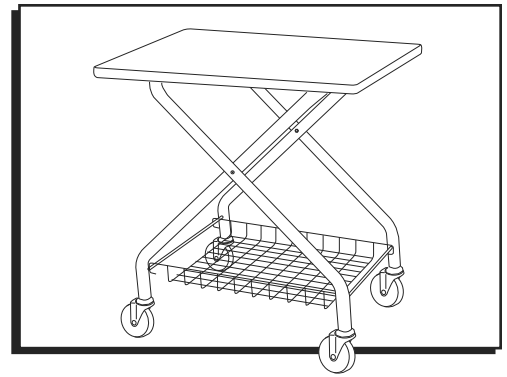

## PARTS

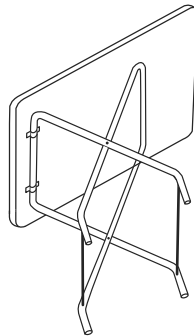

Main Assembly x 1

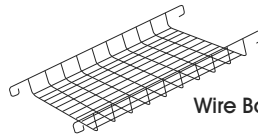

Wire Basket x 1



Swivel Caster x 4

## ASSEMBLY

1. Align swivel casters with caster inserts in main assembly. Tap casters into place with rubber mallet. (See Figure 1)

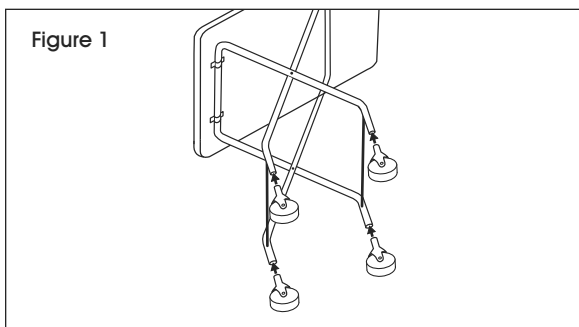

3. Stand cart upright. (See Figure 3)

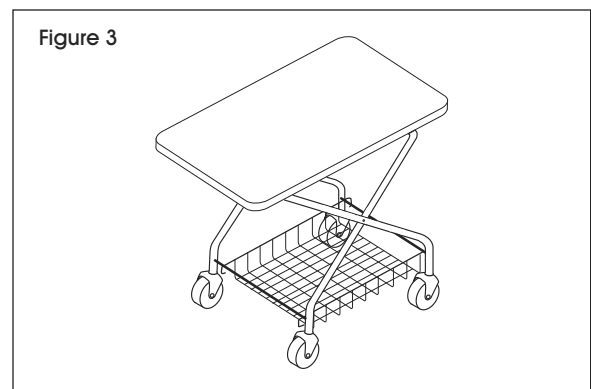

2. Align wire basket with crossbar on wide frame and snap into place. Hook wire basket onto narrow frame. (See Figure 2)

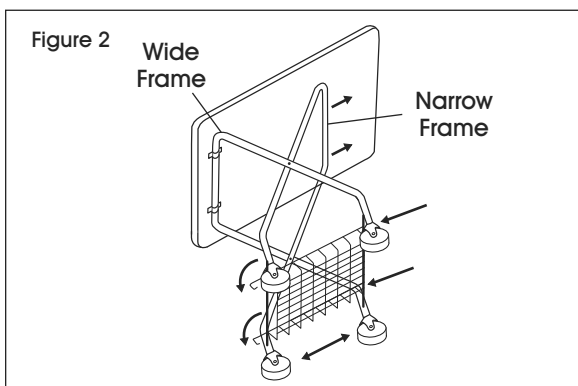

# ULINE H-5070 CARRITO PLEGABLE

800-295-5510  
uline.mx

## HERRAMIENTA NECESARIA



Mazo de Hule

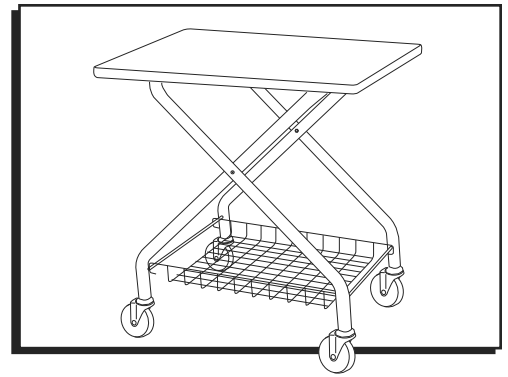

## PARTES

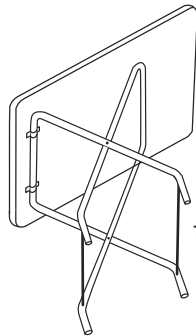

1 Ensamble Principal

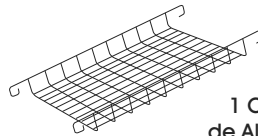

1 Cesta  
de Alambre



4 Ruedas  
Giratorias

## ENSAMBLE

1. Alinee las llantas giratorias con los insertos en el ensamble principal. Inserte las ruedas en su lugar con el mazo de hule. (Vea Diagrama 1)

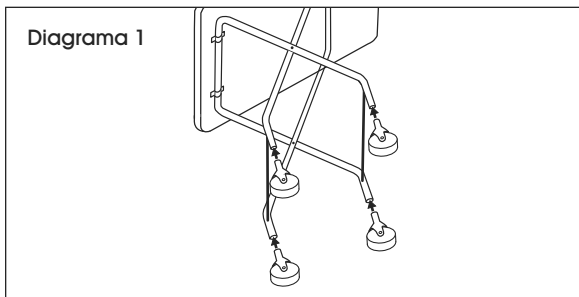

2. Alinee la cesta de alambre con una barra transversal en el marco ancho y ajuste en su sitio. Enganche la cesta de alambre en el marco estrecho. (Vea Diagrama 2)

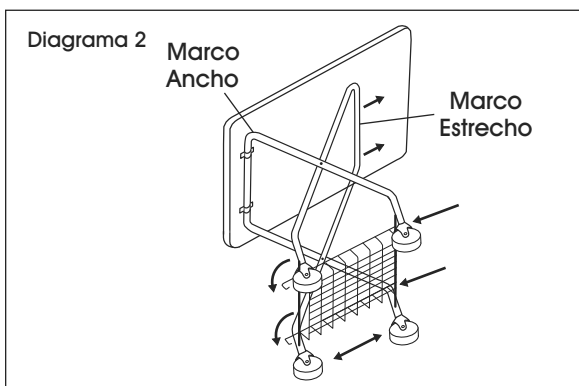

3. Coloque el carrito en posición vertical. (Vea Diagrama 3)

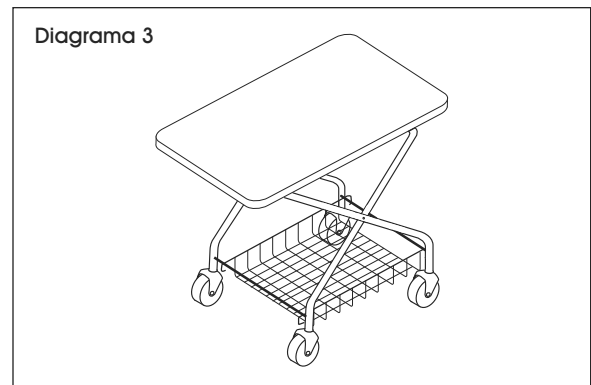

# ULINE H-5070 CHARIOT PLIABLE

1-800-295-5510  
uline.ca

## OUTIL REQUIS



Maillet en caoutchouc

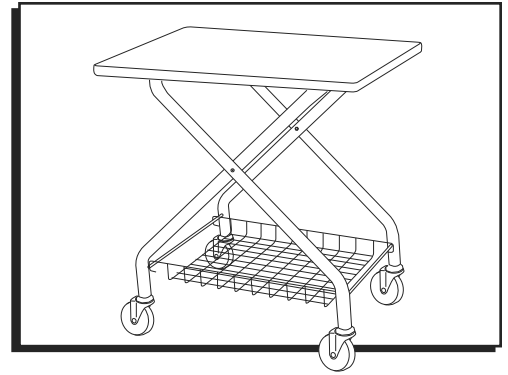

## PARTS

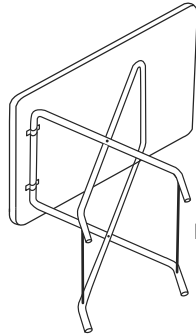

Ensemble principal x 1

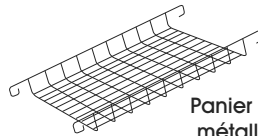

Panier en treillis  
métallique x 1



Roulette  
pivotante x 4

## ASSEMBLY

1. Aligner les roulettes pivotantes avec les embouts pour roulette dans l'ensemble principal. Fixez les roulettes en place avec un maillet en caoutchouc. (Voir Figure 1)

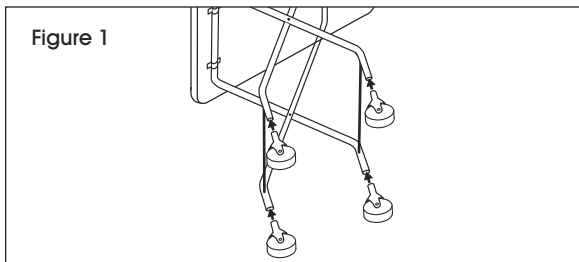

2. Alignez le panier en treillis métallique avec la barre transversale du cadre large de sorte que les deux pièces s'enclenchent l'une dans l'autre. Accrochez le panier en treillis métallique sur le cadre étroit. (Voir Figure 2)

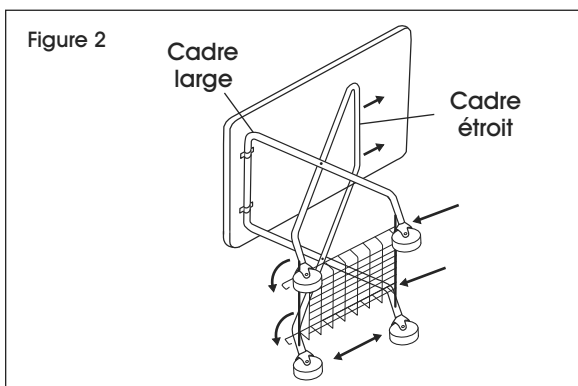

3. Placez le chariot à la verticale. (Voir Figure 3)

