

ULINE H-4810, H-4811 LOCKER LOCKS

1-800-295-5510
uline.com

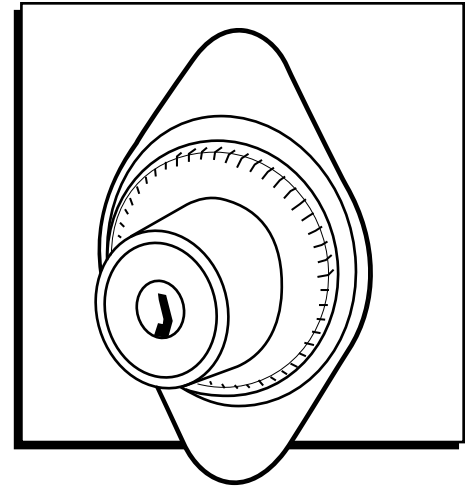

TOOLS NEEDED



7mm Wrench

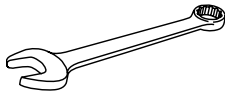

8mm Wrench

INSTALLATION

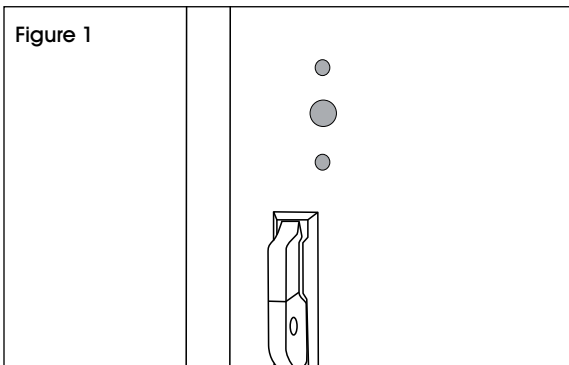

Figure 1

1. Above the handle on the front of the locker, locate the three circular indents. The middle circle will be larger than the top and bottom circles. (See Figure 1)

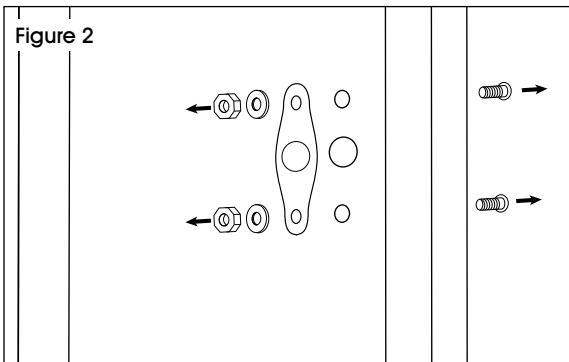

Figure 2

2. Open door. From inside, remove the two nuts and washers holding on the steel plate using a 7mm wrench. Remove the two bolts from the front. (See Figure 2)



NOTE: For Six Tier Uline Industrial Lockers, steel plate is attached to door with rivets. To remove, use a power drill and drill bit to drill out the two rivets holding on the steel plate.

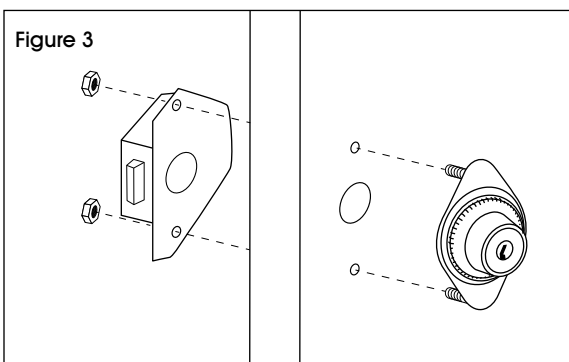

Figure 3

3. To install locker lock, set dial at 0 and remove rear mounting plate of locker lock. Put rear mounting plate up against the inside of the locker door and the front of the lock up against the outside of the door. Push the two pieces together so that mounting bolts stick out through the mounting plate. Secure with nuts and tighten using an 8mm wrench. (See Figure 3)

ULINE H-4810, H-4811

CANDADOS PARA LOCKER

800-295-5510
uline.mx

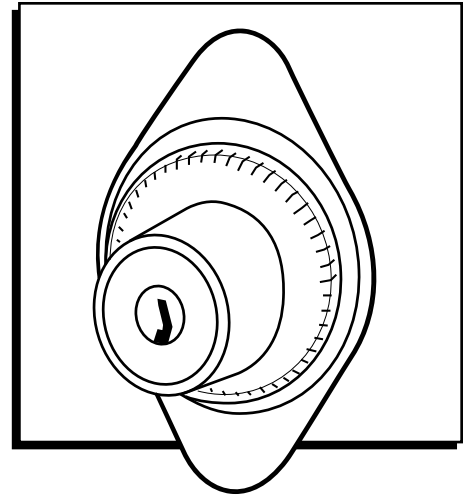

HERRAMIENTAS NECESARIAS



Llave de 7 mm



Llave de 8 mm

INSTALACIÓN

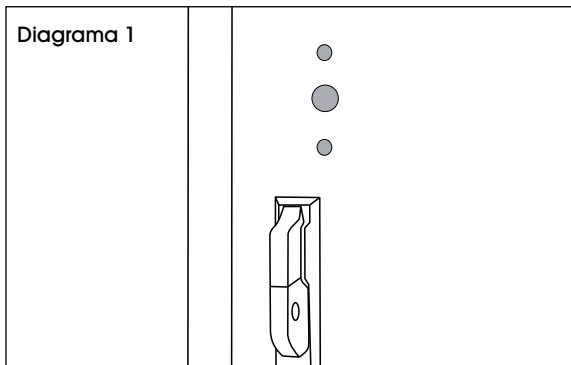

1. Localice las tres muescas circulares ubicadas encima de la manija en la parte delantera del locker. El círculo central será más grande que los círculos superior e inferior. (Vea Diagrama 1)

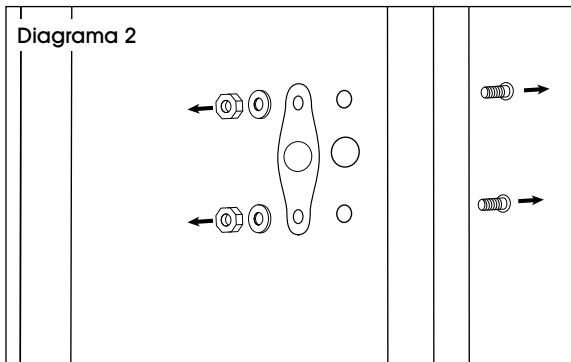

2. Abra la puerta. Desde el interior, quite las dos tuercas y rondanas que sostienen la placa de acero con una llave de 7 mm. Quite los dos pernos desde la parte frontal. (Vea Diagrama 2)



NOTA: Para los Lockers Industriales de Seis Puertas, la placa de acero viene adjunta a la puerta con remaches. Para retirarla, utilice un taladro con broca para remover los dos remaches que sostienen la placa de acero.

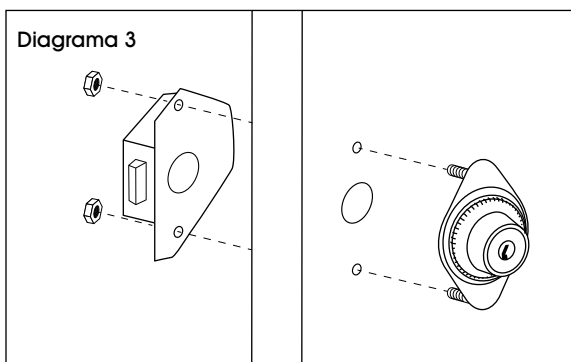

3. Para instalar el candado para locker, coloque el disco en la posición 0 y quite la placa de montaje posterior del candado para locker. Coloque la placa de montaje posterior contra el interior de la puerta del locker y la parte delantera del candado contra el exterior de la puerta. Empuje las dos piezas una contra la otra de forma que los pernos de montaje sobresalgan por la placa de montaje. Fíjelas con tuercas y apriételas usando una llave de 8 mm. (Vea Diagrama 3)

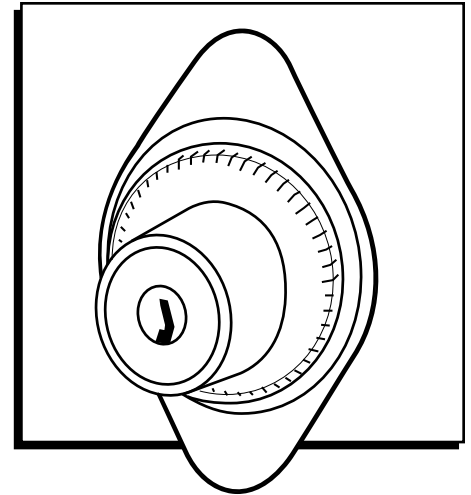

OUTILS REQUIS



Clé de 7 mm

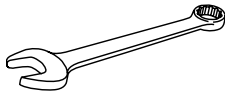

Clé de 8 mm

INSTALLATION

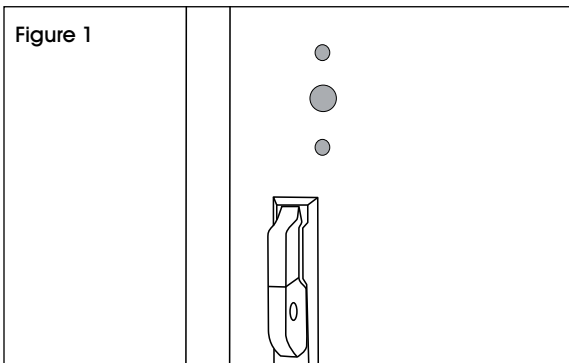

1. Repérez les trois cavités circulaires situées au-dessus de la poignée à l'avant du casier. Le cercle du milieu est plus grand que les cercles supérieur et inférieur. (Voir Figure 1)

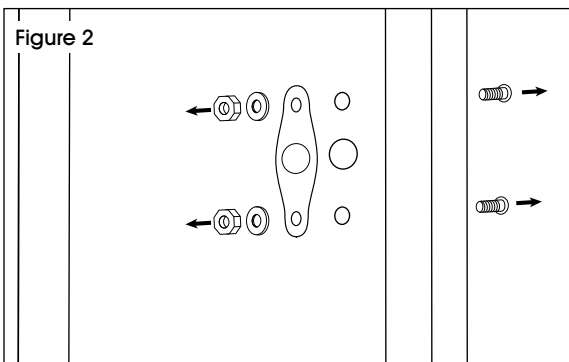

2. Ouvrez la porte. De l'intérieur, retirez les deux écrous et rondelles à l'aide d'une clé de 7 mm en tenant fermement la plaque d'acier. Retirez les deux boulons situés à l'avant. (Voir Figure 2)



REMARQUE : Pour les casiers industriels à six rangées Uline, la plaque d'acier est fixée à la porte avec des rivets. Pour enlever la plaque, utilisez une perceuse électrique et une mèche pour retirer les deux rivets la retenant en place.

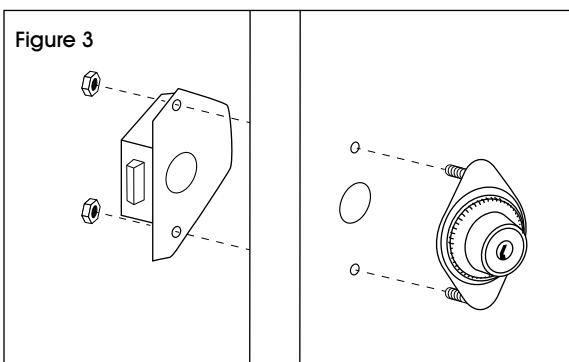

3. Pour installer la serrure de casier, réglez le cadran à 0 et retirez la plaque de montage se trouvant à l'arrière de la serrure de casier. Fixez la plaque de montage arrière contre l'intérieur de la porte du casier et le devant de la serrure contre l'extérieur de la porte. Pressez les deux morceaux l'un contre l'autre de sorte que les boulons de montage traversent la plaque de montage. Fixez à l'aide d'écrous et serrez en vous servant d'une clé de 8 mm. (Voir Figure 3)