

ULINE H-2529, H-2530
H-3373, H-3374
**ALUMINUM PLATFORM
TRUCK**

1-800-295-5510
uline.com

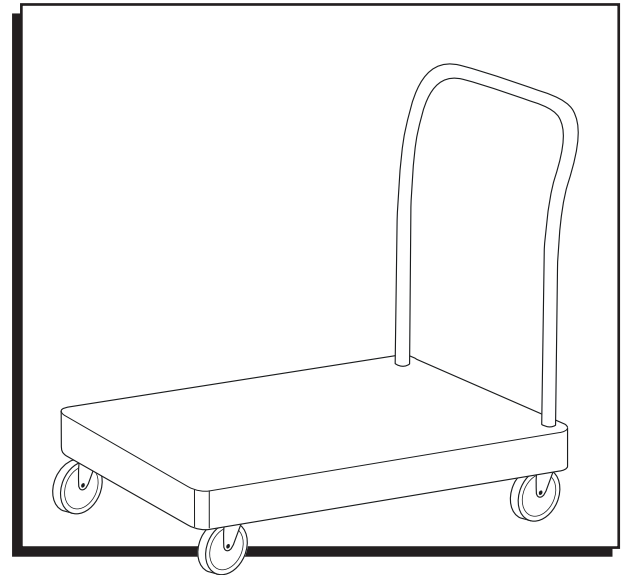

TOOLS NEEDED

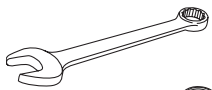

9/16" Wrench

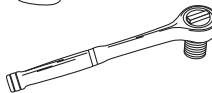

9/16" Socket Wrench

ASSEMBLY

1. Line up mounting holes in caster with the holes in the
caster mounting plate.



NOTE: Nut must be on the caster side of
assembly.

2. Place washers on nut side and install as shown on all
four casters.

3. Tighten all nuts.

4. Insert handle into either end of truck platform.

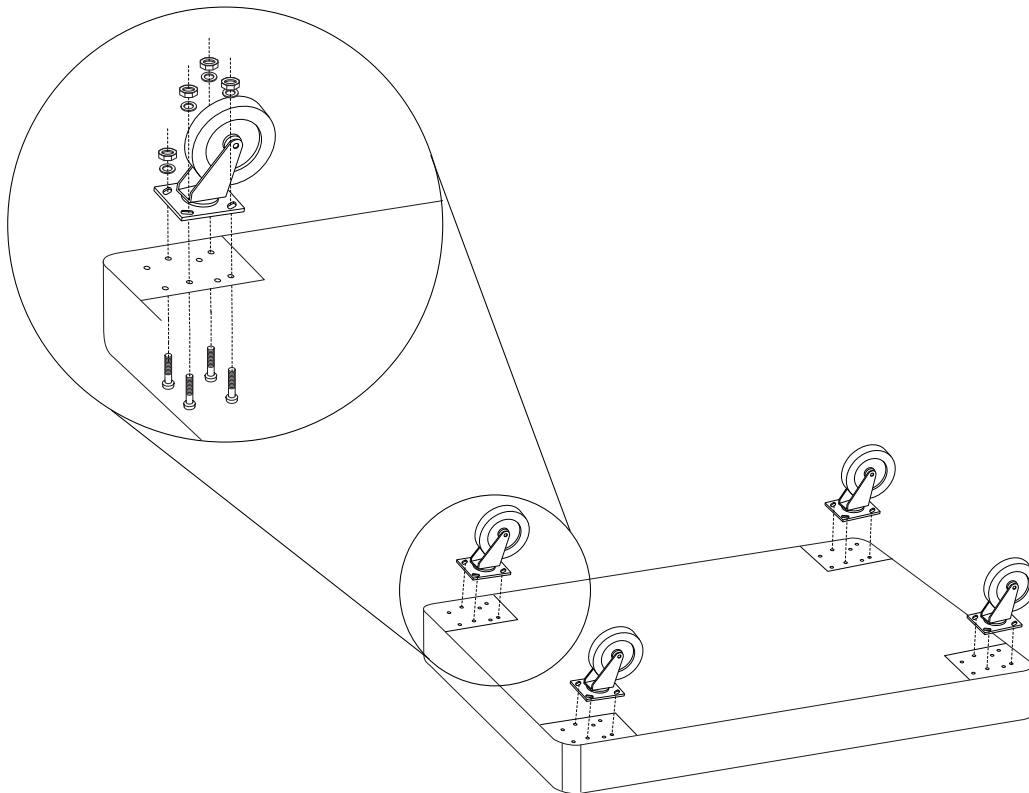

ULINEH-2529, H-2530
H-3373, H-3374800-295-5510
uline.mx

CARRITO CON PLATAFORMA DE ALUMINIO

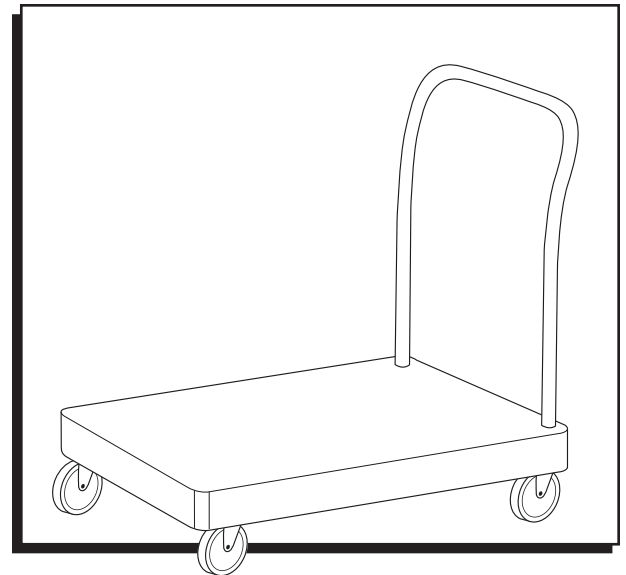

HERRAMIENTAS NECESARIAS

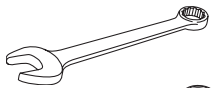

Llave de 9/16"

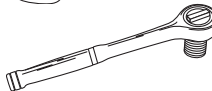

Llave de Dado de 9/16"

ENSAMBLE

1. Alinee los orificios de montaje de las ruedas con los orificios de la placa de montaje de la rueda.



NOTA: La tuerca debe quedar en el lado de la rueda del ensamble.

2. Coloque rondanas en el lado de la tuerca y enrósquelas en las cuatro ruedas como se muestra.

3. Apriete todas las tuercas.

4. Inserte el asa en cualquiera de los extremos de la plataforma del carrito.

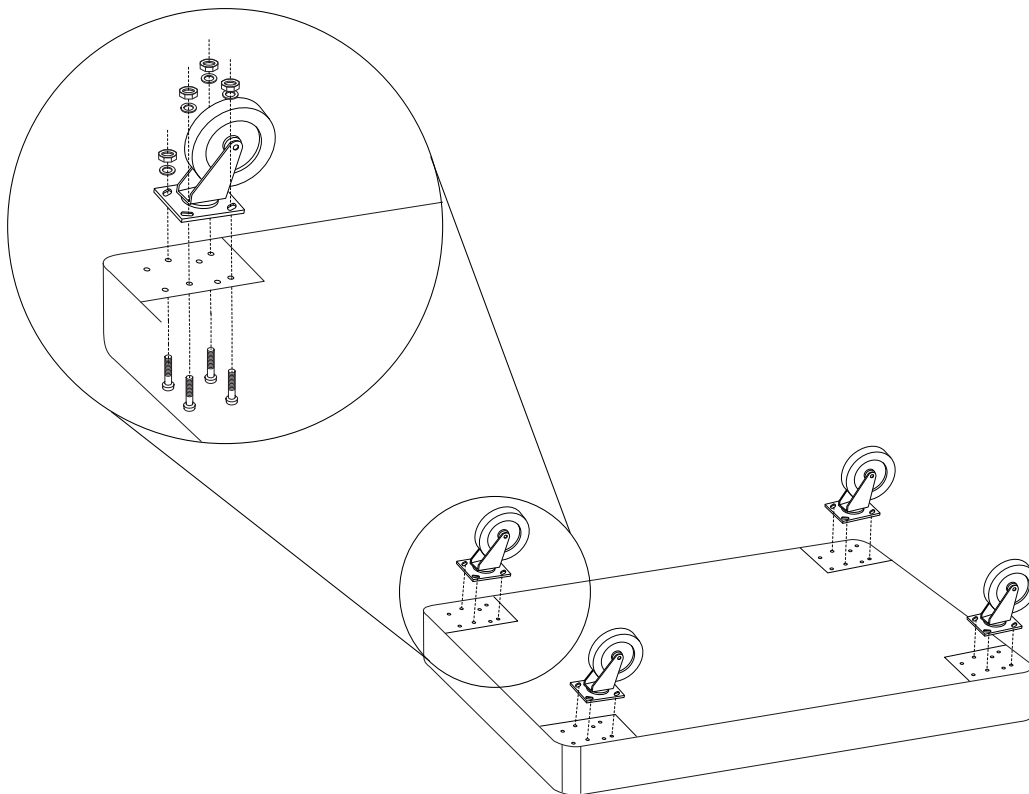

ULINEH-2529, H-2530
H-3373, H-3374

1-800-295-5510

uline.ca

CHARIOT À PLATEFORME EN ALUMINIUM

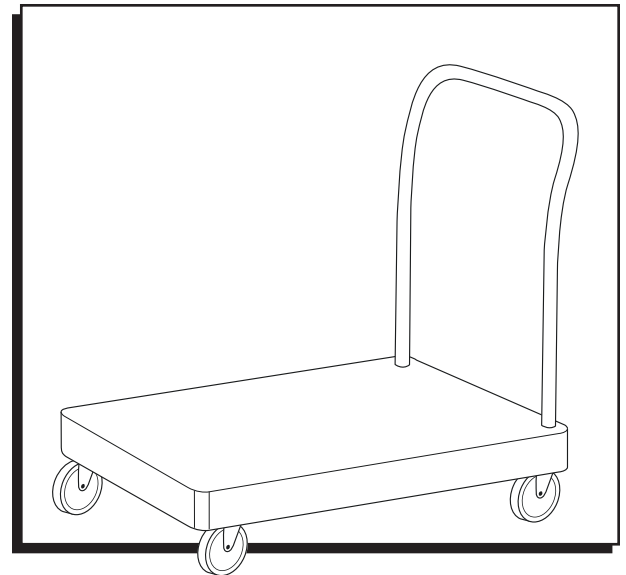

OUTILS REQUIS

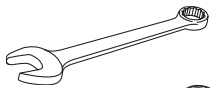

Clé de 9/16 po

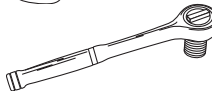

Clé à douilles de 9/16 po

ASSEMBLAGE

1. Alignez les trous de fixation des roulettes avec celles des plaques de fixation pour roulette.



REMARQUE : L'écrou doit être placé du côté de la roulette.

2. Placez les rondelles du côté destiné aux écrous sur les quatre roulettes, comme illustré.

3. Serrez tous les écrous.

4. Insérez la poignée dans une des extrémités de la plateforme du chariot.

